

2 RF PORT MDU NODE [OFMNx-x-x-x-x-x-B-SA-x-x-x/x-x]

Fiber Products, Nodes (1 or 2 RF Output)

Taikan
ESTD. 1973

Description

Taikan's OFMNx Series is a high powered mini node designed for MDU or large facilities that are implementing FTTH and RfOG networks. These mini nodes are offered at 1 GHz and are available in a wide array of return (upstream) transmitters and band splits.

This node is designed in a durable 15 psi pressure tested housing and can have 1 or 2 RF output ports. In addition, an on board equalizer provides the added convenience of slope/tilt setup, minimizing the need for any additional accessories.

The OFMNx is available in a WDM single fiber port version or a more economical dual port version. Each unit includes a separate power adapter that will adhere to the local requirements and a built-in LED to indicate power, optical input and transmit status.



Features

- Low Power Consumption
- Available WDM Technology
- High RF Power Output for 1 or 2 Ports 52/48 dBmV
- Compact Aluminum Alloy Housing
- -20 dB RF Test Ports Forward (Downstream)/Return (Upstream)
- Input/Output Transmit Indicator LED's and Test Ports
- 1310, 1550 or ITU CWDM Return (Upstream) Transmitter Options
- GaAsFET Technology for Low Distortion

Ordering Information

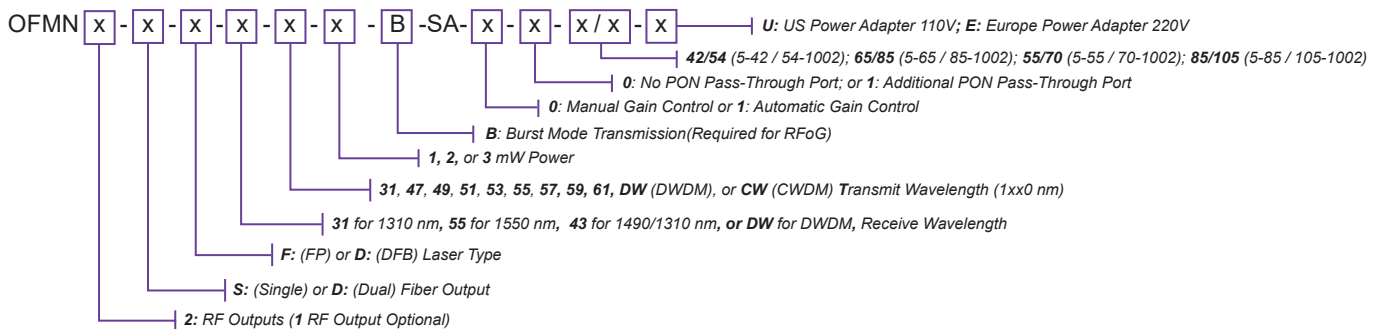

+1430-1610 nm transmit wavelength option only available for single fiber CWDM option

*FP laser only has 31, 55 as transmit wavelength options, DFB laser is available in all wavelengths

Optical Receiver Feature

Optical Wavelength	1270 ~ 1610 nm (Optional WDM 1540 ~ 1565 nm)
Monitor Voltage	1 V/mW
Optical Input Power	-8 to 0 dBm (Optional Automatic Gain Control)

RF/Optical Receiver

Frequency Range	54/85/105 - 1002 MHz
Flatness of Frequency Response	± 0.75 dB
Output Return Loss	16 dB
Reference Output Level	52 dBmV (Optional 1 Port 48 dBmV)
Slope	12 dB (0-18 dB Adjustable)
Optical Input Return Losses	45 dB
C/N	51 dB (-1 dBm Optical Input, 3.5% OMI/ch, 79ch NTSC, Digital ch above 550 MHz at - 6 dB offset)
CTB	-65 dB
CSO	-60 dB

Optical Transmitter Feature

Optical Wavelength	1310, 1610, or CWDM
Optical Output Power	1, 2, or 3 mW
RF Input Level	20-40 dBmV
Dynamic Input Range	20 dB

RF/Optical Transmitter

Frequency Range	5-42/65/85 MHz
Flatness of Frequency Response	± 1 dB
Input Return Loss	16 dB
Optical Output Return Loss	45 dB
Power at which Laser Turns ON	10 dBmV (Burst Mode Parameters can be Customized)
Power at which Laser Turns OFF	-4 dBmV (Burst Mode Parameters can be Customized)

General Specifications

Total Power Consumption (AC)	20 W (100-240 VAC or 40-90 VAC)
Operating Temperature	-40 to 60 °C (-40 to 140 °F) (Humidity 5% to 95%, Non Condensing)
Dimensions	241 x 203 x 117 mm (9.5 x 8.0 x 4.6 in.)

Service Warranty: One Year

© Copyright 2020 Taikan Company Inc. All rights reserved. This document is for information only. Features and specifications are subject to change without notice. v07212020

919 E. 29th St. Lawrence, KS USA 66046 // Phone: 1-800-255-0247 // Fax: 785-841-9512 // sales@taikan.com // www.taikan.com

Taikan